



MOUNT JOY TOWNSHIP

LANCASTER COUNTY, PENNSYLVANIA

Application for Consideration of a Subdivision and/or Land Development Plan

For Mount Joy Township Use Only:

M.J.T.P.C. File No.: 24-08-SLDP	Date of Receipt/Filing: April 1, 2024
School District: X Donegal	Elizabethtown

The undersigned hereby applies for approval under Chapter 119, Subdivision and Land Development, of the Code of the Township of Mount Joy for the Plan submitted herewith and described below:

Plan & Project Information

Plan Name:	Sketch Plan for Mount Joy Town Center		
Plan No.:	4939-50	Plan Date:	April 1, 2024
Location:	Corner of Route 230 and Cloverleaf Road		
Property Owner:	Elizabethtown Associates		
Owner Address:	1000 Germantown Road Suite A-2 Plymouth Meeting, PA 17462		
Telephone No.:			
E-mail:	bob@penmark.com		
Deed Reference:	DEED BK. U, VOL. 71, PG. 21	Tax Parcel No.:	461-00486-0-0000; 461-82176-0-0000
Plan Type:	<input checked="" type="checkbox"/>	<input type="checkbox"/>	<input type="checkbox"/>
	X	Sketch	Preliminary
	<input type="checkbox"/>	<input type="checkbox"/>	<input type="checkbox"/>
	Lot Line Change	Minor Agricultural or Land Development	
Description:	Proposed shopping center with access drives, parking areas, site access from Cloverleaf Road and Route 230. The two lots will be combined into one lot.		
Zoning District:	C-1 Commercial		
Is a zoning change necessary?	Yes	If yes, please specify: Proposal to C-2 Commercial	
Is/was a zoning variance, special exception, or conditional use approval necessary?	Yes	If yes, attach ZHB decision. Pending	
Total Acreage:			
Name of applicant (if other than owner):	same as owner		
Address:			
Telephone No.:			
E-mail:			
Firm which prepared plan:	DC Gohn Associates		
Address:	32 Mount Joy Street Mount Joy, PA 17552		
Phone No.:	717-653-5308		
Person responsible for plan:	Brian R. Cooley		
E-mail:	bcooley@dcgoth.com		

◆ SUPERVISORS ◆ PARK & RECREATION BOARD ◆ PLANNING COMMISSION ◆ ZONING HEARING BOARD

8853 ELIZABETHTOWN ROAD, ELIZABETHTOWN, PA 17022
PHONE (717) 367-8917 –FAX (717) 367-9208
www.mtjoytp.org

Proposed Lots and Units

	# of Lots	# of Units		# of Lots	# of Units
Total #	1		Mixed Use		
Agricultural	1		Single Family Detached		
Commercial			Multifamily (attached-sale)		
Industrial			Multifamily (attached-rental)		
Institutional			Other:		
Total Square Feet of Ground Floor Area (building footprint):			110,650		
Total Square Feet of Existing Structures (all floors):			0		
Total Square Feet of Proposed Structures (all floors):			110,650		
Total Square Feet (or Acres) of Proposed Parkland/Other Public Use:			N/A		
Linear feet of new street:			1,863 lineal feet Norlanco Drive		
Identify all street(s) not proposed for dedication:		Access Drive A, Access Drive B and Access Drive C			

Type of water supply proposed:

<input checked="" type="checkbox"/>	Public (Live)		Community
<input type="checkbox"/>	Public (Capped)		Individual

Type of sanitary sewage disposal proposed:

<input checked="" type="checkbox"/>	Public (Live)		Community
<input type="checkbox"/>	Public (Capped)		Individual

The undersigned hereby represents that, to the best of his knowledge and belief, all information listed above is true, correct and complete.

Signature of Landowner of Applicant

04.01.2024

Date

FILENAME: C:\Users\bcote\AppData\Local\Temp\A\p\17916\SketCh_Plan.dwg XREFS: P:\4939\T\ysom\Zoning\Hearing\Board\3002300PAS_PEMA_2018.rvt IMAGES: P:\4939\T\ysom\Zoning\Hearing\Board\3002300PAS_PEMA_2018.rvt PLOTTED: April 01, 2024 @ 01:03PM

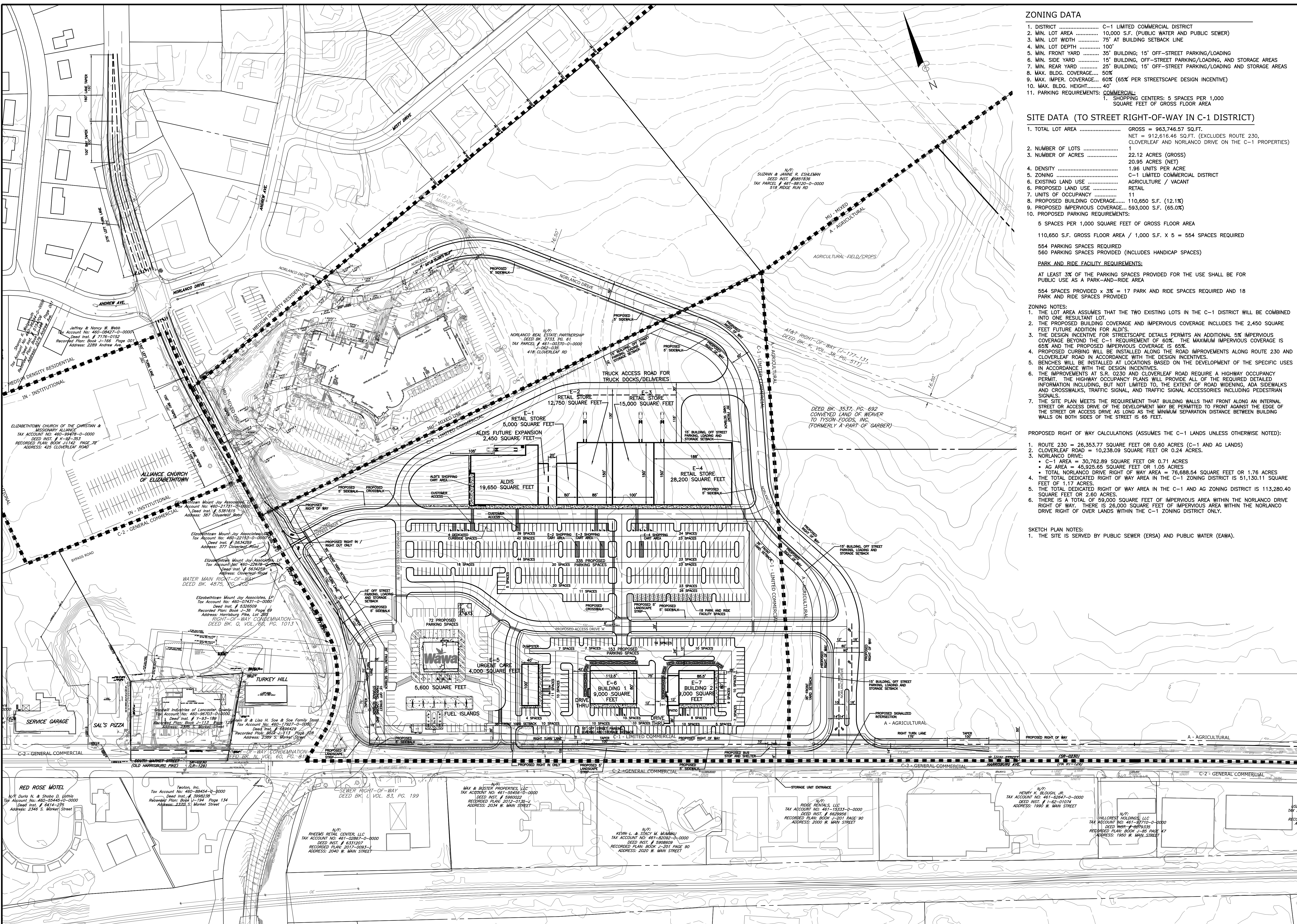

ZONING DATA

- DISTRICT C-1 LIMITED COMMERCIAL DISTRICT
- MIN. LOT AREA 10,000 S.F. (PUBLIC WATER AND PUBLIC SEWER)
- MIN. LOT WIDTH 75' AT BUILDING SETBACK LINE
- MIN. LOT DEPTH 100'
- MIN. FRONT YARD 35' BUILDING; 15' OFF-STREET PARKING/LOADING
- MIN. SIDE YARD 15' BUILDING, OFF-STREET PARKING/LOADING, AND STORAGE AREAS
- MIN. REAR YARD 25' BUILDING; 15' OFF-STREET PARKING/LOADING AND STORAGE AREAS
- MAX. BLDG. COVERAGE 50%
- MAX. IMPER. COVERAGE 60% (65% PER STREETScape DESIGN INCENTIVE)
- MAX. BLDG. HEIGHT 40'
- PARKING REQUIREMENTS: COMMERCIAL:
 - SHOPPING CENTERS: 5 SPACES PER 1,000 SQUARE FEET OF GROSS FLOOR AREA

SITE DATA (TO STREET RIGHT-OF-WAY IN C-1 DISTRICT)

- TOTAL LOT AREA GROSS = 963,746.57 SQ.FT.
NET = 912,616.46 SQ.FT. (EXCLUDES ROUTE 230, CLOVERLEAF AND NORLANCO DRIVE ON THE C-1 PROPERTIES)
- NUMBER OF LOTS 1
- NUMBER OF ACRES 22.12 ACRES (GROSS)
20.95 ACRES (NET)
- DENSITY 1.96 UNITS PER ACRE
- ZONING C-1 LIMITED COMMERCIAL DISTRICT
- EXISTING LAND USE AGRICULTURE / VACANT
- PROPOSED LAND USE RETAIL
- UNITS OF OCCUPANCY 11
- PROPOSED BUILDING COVERAGE 110,650 S.F. (12.1%)
- PROPOSED IMPERVIOUS COVERAGE 593,000 S.F. (65.0%)
- PROPOSED PARKING REQUIREMENTS:
 - 5 SPACES PER 1,000 SQUARE FEET OF GROSS FLOOR AREA

110,650 S.F. GROSS FLOOR AREA / 1,000 S.F. X 5 = 554 SPACES REQUIRED

554 PARKING SPACES REQUIRED
560 PARKING SPACES PROVIDED (INCLUDES HANDICAP SPACES)

PARK AND RIDE FACILITY REQUIREMENTS:

AT LEAST 3% OF THE PARKING SPACES PROVIDED FOR THE USE SHALL BE FOR PUBLIC USE AS A PARK-AND-RIDE AREA

554 SPACES PROVIDED X 3% = 17 PARK AND RIDE SPACES REQUIRED AND 18 PARK AND RIDE SPACES PROVIDED

ZONING NOTES:

- THE LOT AREA ASSUMES THAT THE TWO EXISTING LOTS IN THE C-1 DISTRICT WILL BE COMBINED INTO ONE RESULTANT LOT.
- THE PROPOSED BUILDING COVERAGE AND IMPERVIOUS COVERAGE INCLUDES THE 2,450 SQUARE FEET FUTURE ADDITION FOR ALDIS.
- THE DESIGN INCENTIVE FOR STREETScape DETAILS PERMITS AN ADDITIONAL 5% IMPERVIOUS COVERAGE BEYOND THE C-1 REQUIREMENT OF 60%. THE MAXIMUM IMPERVIOUS COVERAGE IS 65% AND THE PROPOSED IMPERVIOUS COVERAGE IS 65%.
- PROPOSED CURBING WILL BE INSTALLED ALONG THE ROAD IMPROVEMENTS ALONG ROUTE 230 AND CLOVERLEAF ROAD IN ACCORDANCE WITH THE DESIGN INCENTIVES.
- BENCHES WILL BE INSTALLED AT LOCATIONS BASED ON THE DEVELOPMENT OF THE SPECIFIC USES IN ACCORDANCE WITH THE DESIGN INCENTIVES.
- THE IMPROVEMENTS AT S.R. 0230 AND CLOVERLEAF ROAD REQUIRE A HIGHWAY OCCUPANCY PERMIT. THE HIGHWAY OCCUPANCY PLANS WILL PROVIDE ALL OF THE REQUIRED DETAILED INFORMATION INCLUDING, BUT NOT LIMITED TO, THE EXTENT OF ROAD WIDENING, ADA SIDEWALKS AND CROSSWALKS, TRAFFIC SIGNAL, AND TRAFFIC SIGNAL ACCESSORIES INCLUDING PEDESTRIAN SIGNALS.
- THE SITE PLAN MEETS THE REQUIREMENT THAT BUILDING WALLS THAT FRONT ALONG AN INTERNAL STREET OR ACCESS DRIVE OF THE DEVELOPMENT MAY BE PERMITTED TO FRONT AGAINST THE EDGE OF THE STREET OR ACCESS DRIVE AS LONG AS THE MINIMUM SEPARATION DISTANCE BETWEEN BUILDING WALLS ON BOTH SIDES OF THE STREET IS 65 FEET.

PROPOSED RIGHT OF WAY CALCULATIONS (ASSUMES THE C-1 LANDS UNLESS OTHERWISE NOTED):

- ROUTE 230 = 26,353.77 SQUARE FEET OR 0.60 ACRES (C-1 AND AG LANDS)
- CLOVERLEAF ROAD = 10,238.09 SQUARE FEET OR 0.24 ACRES.
- NORLANCO DRIVE:
 - C-1 AREA = 30,762.89 SQUARE FEET OR 0.71 ACRES
 - AG AREA = 45,925.69 SQUARE FEET OR 1.05 ACRES
 - TOTAL NORLANCO DRIVE RIGHT OF WAY AREA = 76,688.54 SQUARE FEET OR 1.76 ACRES
- THE TOTAL DEDICATED RIGHT OF WAY AREA IN THE C-1 ZONING DISTRICT IS 51,130.11 SQUARE FEET OF 1.17 ACRES.
- THE TOTAL DEDICATED RIGHT OF WAY AREA IN THE C-1 AND AG ZONING DISTRICT IS 113,280.40 SQUARE FEET OR 2.60 ACRES.
- THERE IS A TOTAL OF 69,000 SQUARE FEET OF IMPERVIOUS AREA WITHIN THE NORLANCO DRIVE RIGHT OF WAY. THERE IS 28,000 SQUARE FEET OF IMPERVIOUS AREA WITHIN THE NORLANCO DRIVE RIGHT OF WAY WITHIN THE C-1 ZONING DISTRICT ONLY.

SKETCH PLAN NOTES:

- THE SITE IS SERVED BY PUBLIC SEWER (ERSA) AND PUBLIC WATER (EAWA).

OWNER: TRACT 1 AND TRACT 2	OWNER: PREMISE A AND PREMISE B	OWNER: TRACT 1 AND TRACT 2	OWNER: TRACT 1 AND TRACT 2
NAME: ELIZABETHTOWN ASSOCIATES	NAME: ELIZABETHTOWN ASSOCIATES	NAME: ELIZABETHTOWN ASSOCIATES, LP	NAME: ELIZABETHTOWN ASSOCIATES, LP
ADDRESS: 1000 GERMANTOWN RD SUITE A - 2	ADDRESS: 1000 GERMANTOWN RD SUITE A - 2	ADDRESS: 1000 GERMANTOWN RD SUITE A - 2	ADDRESS: 1000 GERMANTOWN RD SUITE A - 2
ADDRESS: PLYMOUTH MEETING, PA 19462	ADDRESS: PLYMOUTH MEETING, PA 19462	ADDRESS: PLYMOUTH MEETING, PA 19462	ADDRESS: PLYMOUTH MEETING, PA 19462
SOURCE OF TITLE: DEED BK. U. VOL. 71, PG. 21	SOURCE OF TITLE: DEED BK. U. VOL. 71, PG. 21	SOURCE OF TITLE: DEED INST. # 5160060	SOURCE OF TITLE: DEED INST. # 5160061
LANC. CO. TAX ACCT.: 461-00486-0-0000	LANC. CO. TAX ACCT.: 461-00486-0-0000	LANC. CO. TAX ACCT.: 461-41585-0-0000	LANC. CO. TAX ACCT.: 461-95417-0-0000
Survivors - Engineers - Landscape Architects			
PROJECT NO.: 4939-50	DATE: APRIL 1, 2024	DRAWN BY: BRC	CHECKED BY: BRC
SCALE: 1"=100' 			
PROPOSED SKETCH PLAN PROPOSED SITE PLAN FOR MOUNT JOY TOWN CENTER PENNMARK MANAGEMENT COMPANY MOUNT JOY TOWNSHIP LANCASTER COUNTY, PENNSYLVANIA			
DRAWING #: CG-2991A			
SHEET #: 2 OF 4			

FILENAME: C:\Users\bcocote\AppData\Local\Temp\AcP\Utilshp_17916\SketCh_Plan.dwg XREFS: IMAGES: P:\4939\T\ymon\Zoning\Hearing_Board\3000200PAS_FEMA_2018_IP2 IMAGES: P:\4939\T\ymon\Zoning\Hearing_Board\3000200PAS_FEMA_2018_IP2 PLOTTED: April 01, 2024 @ 01:03PM

[2] Design Resources

Basic Bus Stop Elements

Bus stop elements are curbside facilities located at a bus stop to provide safe access to the bus service, make the stop visible, and enhance the comfort of waiting passengers.

- 1 ADA Loading Pad**
 - Firm and stable surface
 - Minimum clear length of 8' measured perpendicular to the roadway
 - Minimum clear width of 5' measured parallel to the roadway
- 2 Informational Signage**
 - Minimum 2' between the sign support and the curb/edge of the roadway
 - Not obstructing pedestrian route
 - Mounted on a post (or a shelter) that does not include any traffic control devices
- 3 Shelter, Bench, Bicycle Parking, Lighting, Trash Receptacle, and other Amenities (optional)**
 - Locate amenities to ensure they do not obstruct access to the bus stop or the pedestrian access route
 - Consider maintenance responsibilities and requirements before installation
- 4 Accessible Route**
 - Desirable minimum width of 4' with a required minimum clear width of 3'
- 5 Accessible Route (through the stop and to destinations)**
 - Firm, stable, and slip resistant surface
 - Desirable minimum width of 5' with a required minimum clear width of 4'
- 6 Clear Zone for Rear Door and Waiting Area**
 - Level area free of obstructions to wait for the bus and access the bus via the rear door
- 7 No Parking Signs or Designation (if applicable)**
 - No parking may be designated with signs, painted curbs, and/or pavement markings
 - Municipalities are responsible for no parking designations

Additional notes for 6: Locate trees, landscape, and stormwater management features to ensure they do not obstruct access for pedestrians or visibility.

Building Better Bus Stops Resource Guide Quick Reference pcta.net/pages/betterbusstops

**SOUTH CENTRAL TRANSIT AUTHORITY NOTES:
GUIDELINES FOR BUS STOPS AND BUS SHELTERS
(Updated 1/24/2022)**

CONSTRUCTION OF BUS STOP AND CONCRETE PAD FOR SHELTER

The construction of the bus stop will be done in accordance with local construction requirements and guidelines with consideration of the ADA Standards and Guidelines.

- The bus shelter supplier provides specifications for the construction of the concrete pad. The typical pad concrete specifications listed below may be modified based on the requirements of an individual supplier, project need and local construction requirements and guidelines.
 - Size of concrete pad will depend on the size of the shelter installed. Example: for a 5 FT x 8 FT shelter the recommended concrete pad measures a minimum of 6 FT x 10 FT.
 - Concrete pads to be 3000 PSI concrete 6 inches to 8 inches thick, 3 inch to 4 inch slump and 5 - 7% air entrained.
 - 1/4 inch gravel - 4 inches to 6 inches deep underlay.
 - Fiberglass mesh screen or steel re-bar for re-enforcement.
 - Fiber board at perimeter and expansion joints when pad exceeds 12 FT in length.
 - Exposed edges to have a 1 inch chamfer.
 - Pad surface shall be broom finished.
 - Shelters must be grounded as per local electrical codes.
 - Minimum 21 day slab cure prior to bus shelter anchor installation.

CONSTRUCTION OF BOARDING AND ALIGHTING AREA

The construction of a Boarding and Alighting Area will be done in accordance with local construction requirements and guidelines with consideration of the ADA Standards and Guidelines.

ADA STANDARDS AND GUIDELINES

The following information regarding the applicable ADA Standards and Guidelines is provided as a summary reference. The documents referenced below shall be consulted if there are detailed questions or a need for interpretation. Construction that occurs shall be done in accordance with the ADA Standards and Guidelines as described in the reference documents.

Boarding and Alighting Area

For an accessible bus stop, SCA needs a boarding and alighting area for the deployment of the bus ramp that is a minimum of 60 inches long parallel to the roadway and a minimum of 96 inches perpendicular to the roadway from the curb. If the project has a grass strip between the curb and sidewalk, the concrete boarding and alighting area must cover the grass area between the curb and sidewalk.

In order to meet the requirement for a boarding and alighting area at a bus stop, there is typically no need to depress the boarding and alighting area and curb in order for the bus stop area to be level with the street pavement. The boarding and alighting area will be constructed and incorporated as part of the typical construction of the curb and sidewalk.

Parallel to the roadway the slope of the boarding and alighting area is the same as the roadway to the maximum extent practicable. Perpendicular to the roadway the slope is $\leq 1:48$ (2.1%).

Connections

Bus stop boarding and alighting areas and bus shelters shall be connected to streets, sidewalks or pedestrian paths by an accessible route complying with ADA standards.

Bus Shelters

The bus shelter shall be connected by an accessible route complying with ADA standards to the bus stop boarding and alighting area.

Clear floor space of ≥ 30 inches by ≥ 48 inches entirely within the shelter.

One side of the clear floor space shall adjoin an accessible route.

If the clear floor space is confined on any of the three sides, width ≥ 36 inches for front approach or length ≥ 60 inches for parallel approach.

For the clear floor space, the surface shall be stable, firm and slip resistant and no changes in level $> 1/4$ inch.

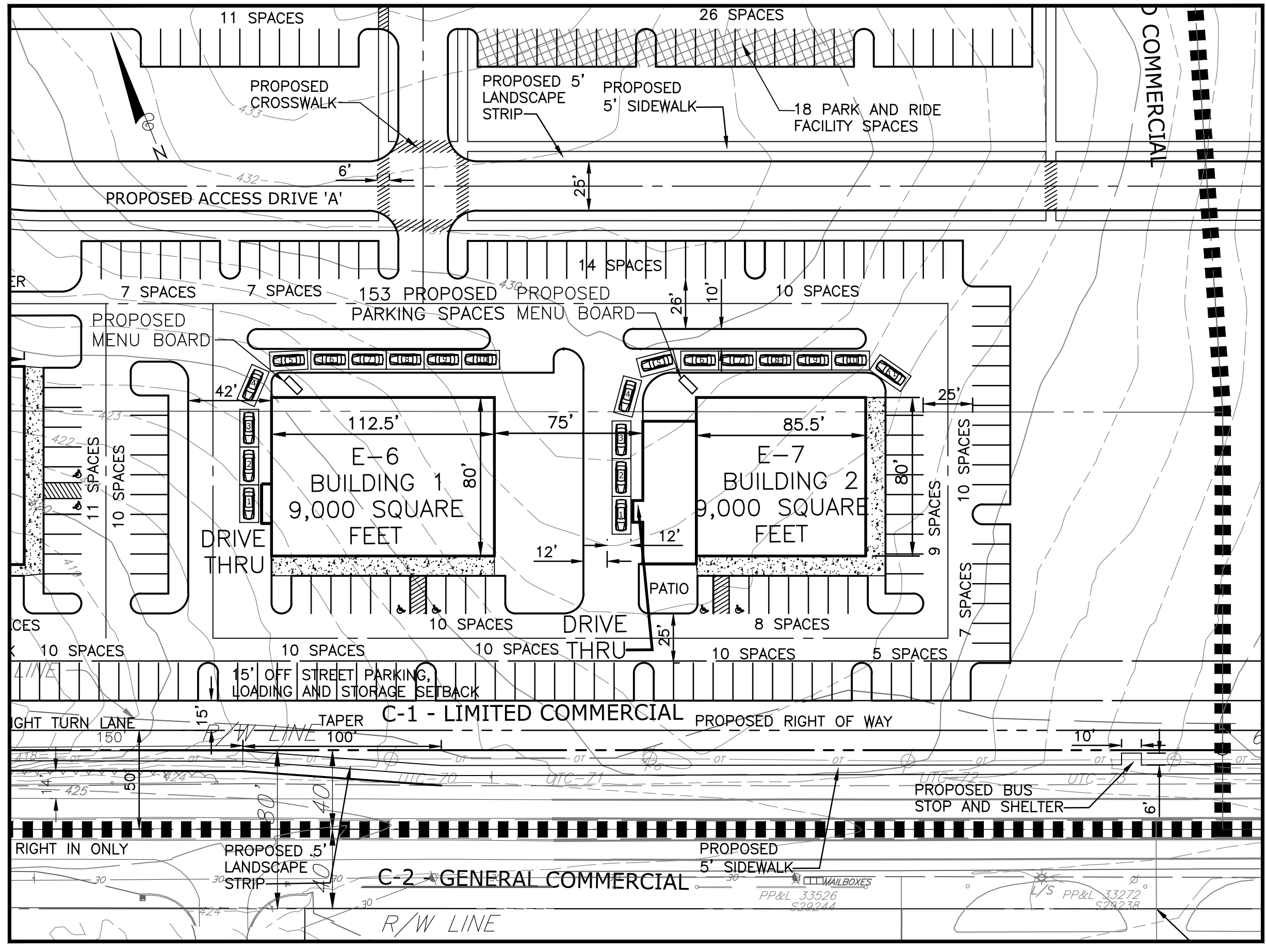

- GENERAL NOTES:**
- Zoning Code
 - The minimum lot size shall be one acre.
 - A vehicle stacking lane area shall be provided which shall have stacking room for at least six vehicles for restaurant uses and at least three vehicles for retail and financial institutions.
 - Vehicle stacking lanes shall be separated from other vehicle circulation lanes and parking areas and the stacking area shall not be counted towards the required parking.
 - Vehicle stacking lanes shall be set back at least 15 feet from the ultimate street right-of-way and shall not be located within a required yard setback.
 - Any outdoor microphone and speaker system shall be so designed that sound shall not be transmitted to adjoining properties.
 - Location.
 - Drive-through windows designed to be on the rear- or side-facing wall of a building are permitted.
 - The Zoning Hearing Board may permit drive-through windows on the front-facing wall of a building by special exception, in accordance with the following criteria:

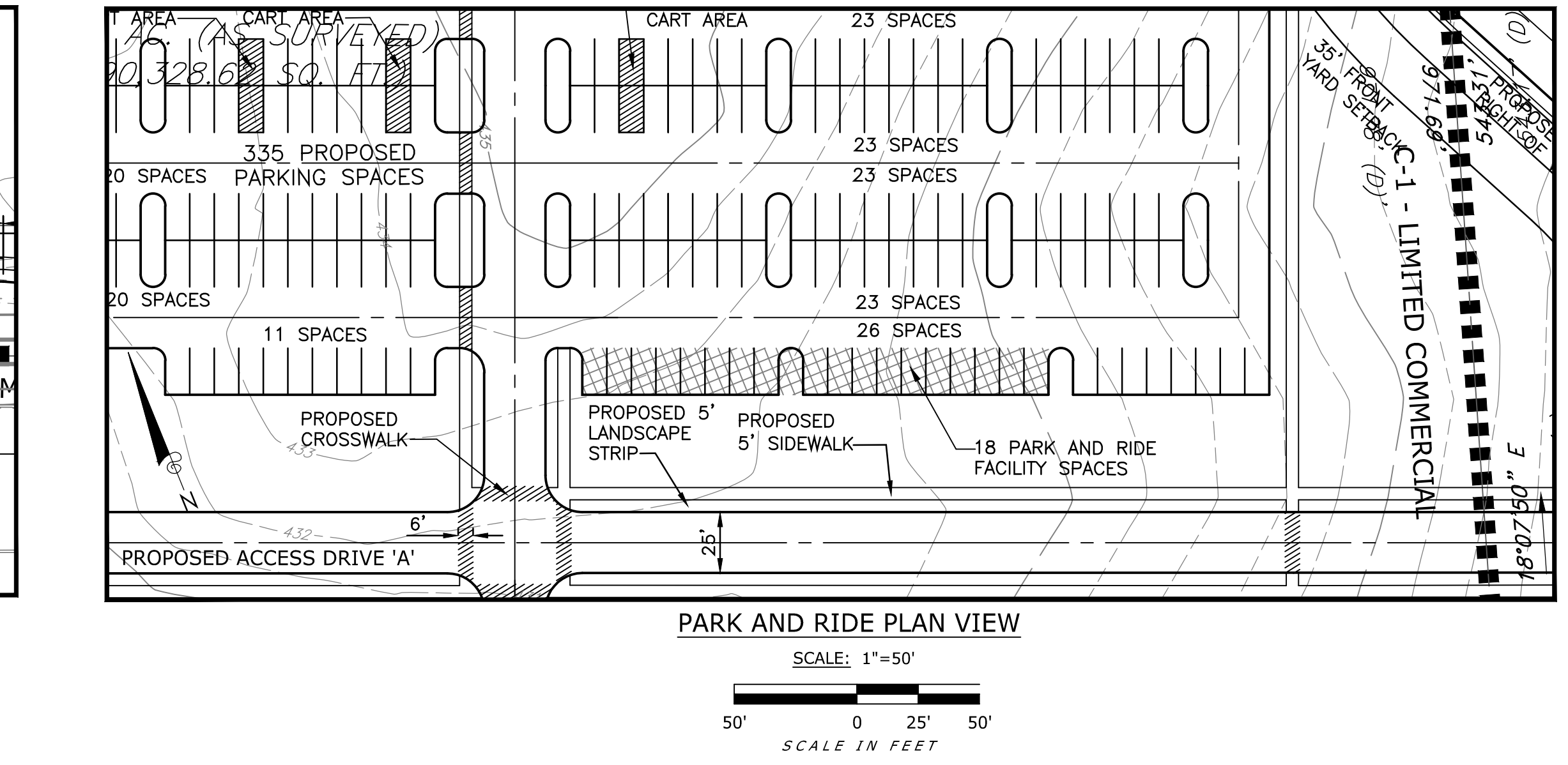
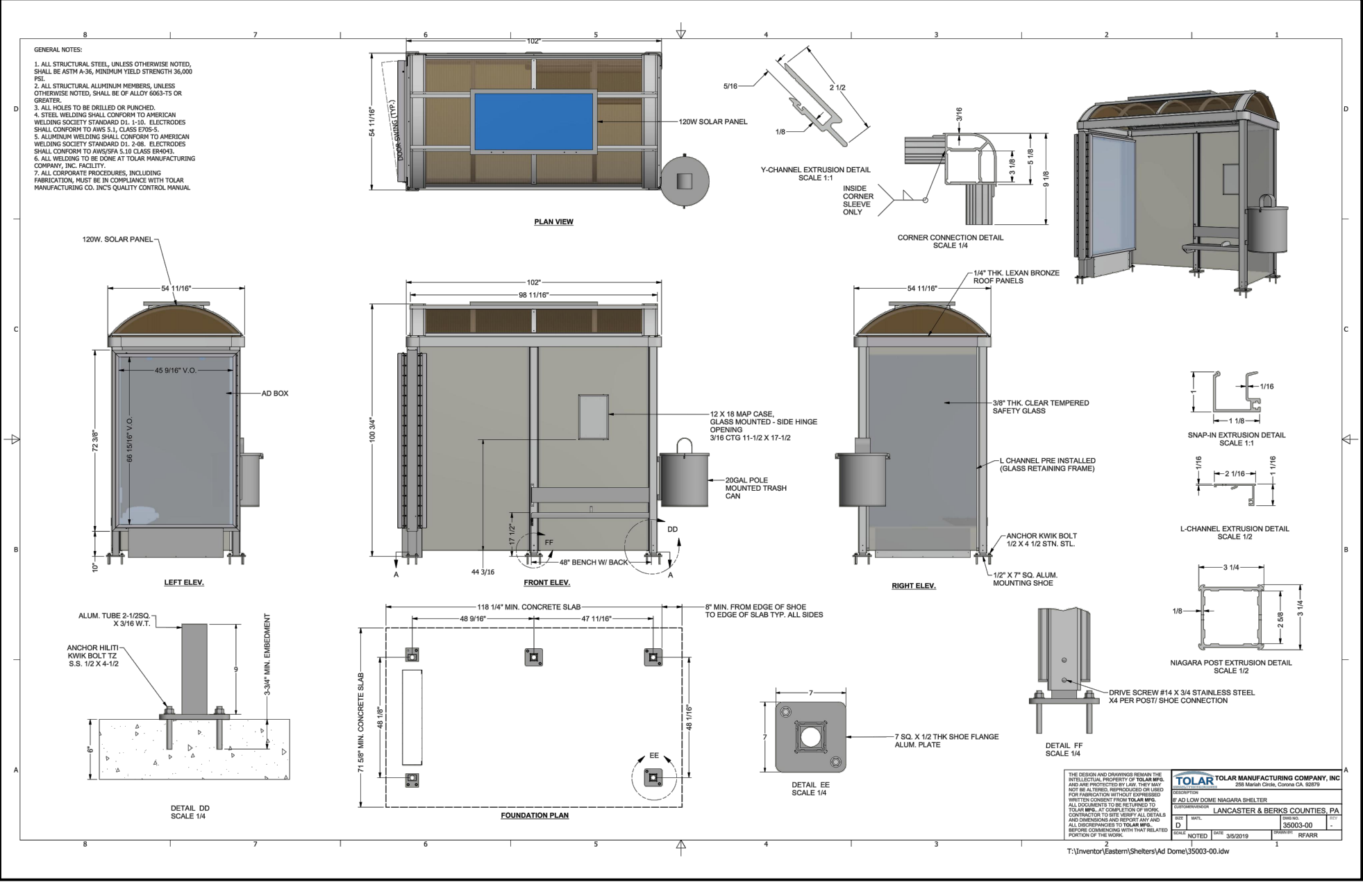

OWNERS: TRACT 1 AND TRACT 2 NAME: ELIZABETHTOWN MOUNT JOY ASSOCIATES, LP ADDRESS: 1000 GERMANTOWN RD SUITE A - 2 PLYMOUTH MEETING, PA 19462	SOURCE OF TITLE: DEED INST. # 5160060 LANC. CO. TAX ACCT.: 461-4155-0-000	OWNERS: PREMISE A AND PREMISE B NAME: ELIZABETHTOWN ASSOCIATES ADDRESS: 1000 GERMANTOWN RD SUITE A - 2 PLYMOUTH MEETING, PA 19462	SOURCE OF TITLE: DEED BK. U. VOL. 71, PG. 21 LANC. CO. TAX ACCT.: 461-00486-0-000	OWNERS: ELIZABETHTOWN MOUNT JOY ASSOCIATES, LP ADDRESS: 1000 GERMANTOWN RD SUITE A - 2 PLYMOUTH MEETING, PA 19462	SOURCE OF TITLE: DEED INST. # 5160061 LANC. CO. TAX ACCT.: 461-4155-0-000	OWNERS: ELIZABETHTOWN ASSOCIATES ADDRESS: 1000 GERMANTOWN RD SUITE A - 2 PLYMOUTH MEETING, PA 19462	SOURCE OF TITLE: DEED BK. U. VOL. 71, PG. 21 LANC. CO. TAX ACCT.: 461-82176-0-000
<p>PROPOSED SKETCH PLAN FOR MOUNT JOY TOWN CENTER PENNMARK MANAGEMENT COMPANY MOUNT JOY TOWNSHIP LANCASTER COUNTY, PENNSYLVANIA</p> <p>DRAWING #: CG-2991A SHEET #: 3 OF 4</p>							

djohn Associates, Inc.
Surveyors - Engineers - Landscape Architects

32 Mount Joy Street
Po Box 128
Mount Joy, PA 17552
PH: (717) 653-5308
www.djohn.com

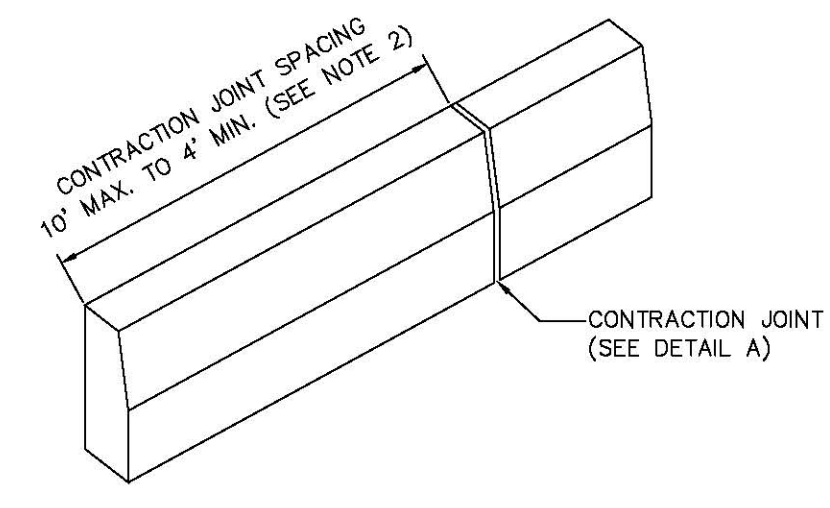
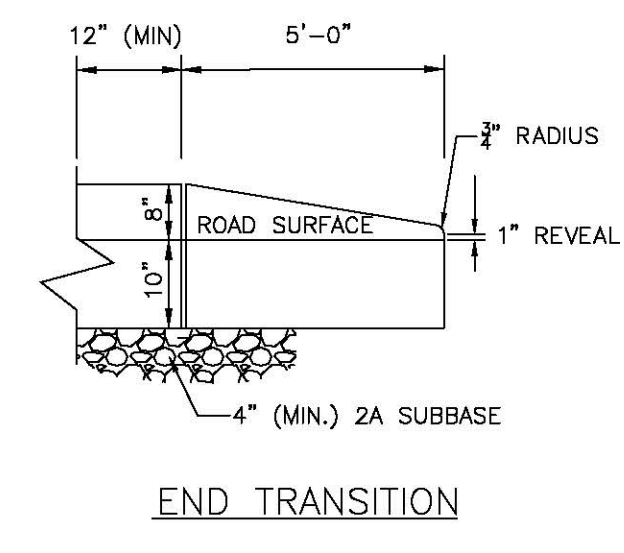
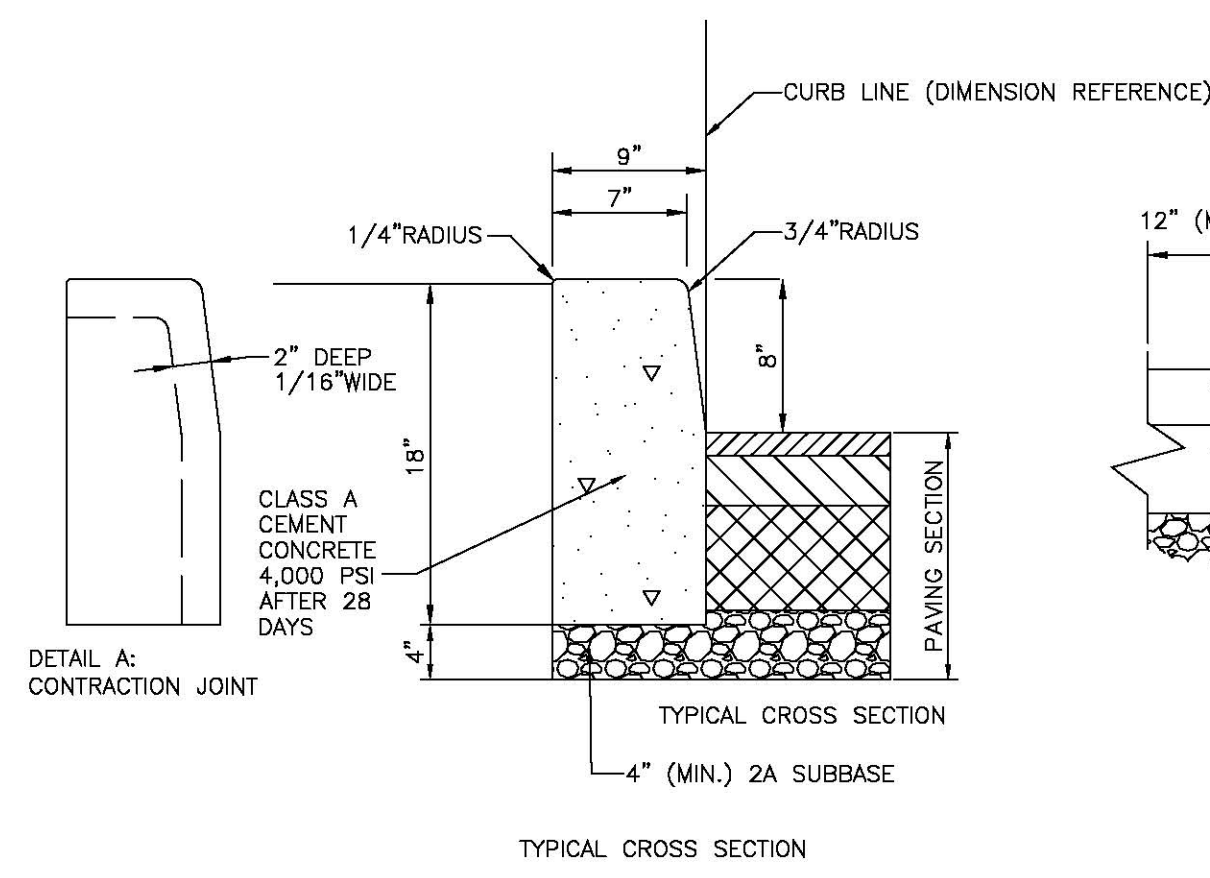

8" PLAIN CONCRETE CURB DETAIL
NOT TO SCALE

- CONSTRUCTION NOTES:**
- MATERIALS AND CONSTRUCTION SHALL MEET THE REQUIREMENTS OF PUBLICATION 408, SECTION 630.
 - PLACE 3/4" INCH PREMOLDED EXPANSION JOINT FILLER MATERIAL AT STRUCTURES AND AT THE END OF THE WORK DAY. CUT MATERIAL TO CONFORM TO AREA ADJACENT TO CURB OR TO CONFORM TO CROSS SECTIONAL AREA OF CURB.
 - SPACERS/JOINTS SHOULD BE ASPHALT, NOT CARDBOARD FILLER.
 - ALL VERTICAL CURBING SHALL BE MACHINE-FORMED. THE REQUIRED HEIGHT FOR HAND-FORMED CURB IS 24".
 - EXPANSION JOINTS ARE REQUIRED EVERY 60 FEET AND 10 FEET ON EITHER SIDE OF STRUCTURES. IN ADDITION TO ON EITHER SIDE OF STRUCTURES AND AT THE END OF EACH DAY'S WORK.

- GENERAL NOTES:**
- Zoning Code
 - Concrete curbs shall be provided along the edge of a street cartway. If a new or existing street divides the development tract, concrete curbs shall be provided on both sides of the road.
 - All curbs shall be in accordance with Township specifications.
- Township Specifications**
- Concrete curbs shall be provided for all subdivisions and land developments along street frontages, access drives, and along the edge of any landscaped portions of a parking facility. For developments located outside the designated growth area, curbing shall not be required along all street frontages, access drives and along the edge of any landscaped portion of a parking facility, unless the Township Engineer determines it is necessary for stormwater management and control purposes. Concrete curbs may be required by the Township in subdivisions and land developments outside the designated growth area in the following locations:
 - Along the radius of each corner of all street intersections.
 - Along the radii of all access drive intersections with a street, which shall contain a minimum of a five-foot taper at the end of the radii.
 - Along streets where sidewalks exist or are proposed.
 - Construction standards.
 - All curbs shall be constructed in accordance with the specifications located in Appendix No. 16[3] and the most current editions of PennDOT Publication Form 408, Specifications, and PennDOT Publication No. 72, Standards for Roadway Construction, and in accordance with any regulations adopted by the state or federal government concerning handicapped accessibility.
 - Supplementing Appendix No. 16 and PennDOT specifications and standards, the following construction and repair practices shall be followed:
 - Construction of driveway and pedestrian ramps shall be consistent with the design standards set forth in PennDOT Publication No. 72 for curb ramps. Pedestrian ramp locations will be where directed by the Township Engineer.
 - Vertical curbs shall be installed unless the Township Engineer, for cause shown, permits the use of slant curbs. Cost shall not be considered cause warranting use of slant curbs.
 - Curbing shall be designed to provide a ramp cut at each intersection of a vehicular travelway, at the principal entrances to buildings which front on parking lots, and at all crosswalks.
 - Any transition between curbing types shall be at the discretion of the Township and shall be subject to final approval by the Township Engineer.
 - Curb construction shall meet all applicable standards of the latest edition of the Americans with Disabilities Act (ADA)

RECEIVED
Apr 01 2024
MOUNT JOY TOWNSHIP

<p>PROPOSED SKETCH PLAN PROPOSED PLAN NOTES AND DETAILS</p>		<p>PROJECT NO.: 4939-50 DATE: APRIL 1, 2024 DRAWN BY: BRC CHECKED BY: BRC SCALE: AS NOTED</p>
<p>FOR MOUNT JOY TOWN CENTER PENNMARK MANAGEMENT COMPANY MOUNT JOY TOWNSHIP LANCASTER COUNTY, PENNSYLVANIA</p>		<p>dcjohn Associates, Inc. Surveyors - Engineers - Landscape Architects</p> <p>32 Mount Joy Street Po Box 128 Mount Joy, PA 17552 PH: (717) 653-5308 www.dcgohn.com</p>
<p>OWNERS: TRACT 1 AND TRACT 2 NAME: ELIZABETHTOWN MOUNT JOY ASSOCIATES, LP ADDRESS: 1000 GERMANTOWN RD SUITE A - 2 PLYMOUTH MEETING, PA 19462 SOURCE OF TITLE: DEED INST. #5160060 LANC. CO. TAX ACCT.: 461-00486-0-0000</p>		<p>OWNERS: PREMISE A AND PREMISE B NAME: ELIZABETHTOWN ASSOCIATES ADDRESS: 1000 GERMANTOWN RD SUITE A - 2 PLYMOUTH MEETING, PA 19462 SOURCE OF TITLE: DEED BK. U, VOL. 71, PG. 21 LANC. CO. TAX ACCT.: 461-00486-0-0000</p>
<p>OWNERS: TRACT 1 AND TRACT 2 NAME: ELIZABETHTOWN MOUNT JOY ASSOCIATES, LP ADDRESS: 1000 GERMANTOWN RD SUITE A - 2 PLYMOUTH MEETING, PA 19462 SOURCE OF TITLE: DEED INST. #5160060 LANC. CO. TAX ACCT.: 461-41555-0-0000</p>		<p>OWNERS: TRACT 1 AND TRACT 2 NAME: ELIZABETHTOWN MOUNT JOY ASSOCIATES, LP ADDRESS: 1000 GERMANTOWN RD SUITE A - 2 PLYMOUTH MEETING, PA 19462 SOURCE OF TITLE: DEED INST. #5160061 LANC. CO. TAX ACCT.: 461-95417-0-0000</p>
<p>DRAWING #: CG-2991A SHEET #: 4 OF 4</p>		<p>REVISIONS DATE</p>

April 18, 2024

Justin Evans, AICP
Township Manager
Mount Joy Township
8853 Elizabethtown Road
Elizabethtown, PA 17022



LANCASTER CIVIL
★ ★ *engineering company* ★ ★
p.o. box 8972, lancaster, pa 17604-8972
www.lancastercivil.com

Re: Penmark Management Company
Proposed Site Plan (Zoning Hearing Board application)
LCEC Project No: 25-127

Dear Mr. Evans,

We have received a sketch plan submission from D.C. Gohn Associates, Inc. for the above-referenced project. The submission consisted of the following documents:

- Sketch Plan Submission Letter dated April 1, 2024
- Proposed Sketch Plan dated April 1, 2024

Based upon my review of the submitted information, I offer the following comments for the Township to consider:

Zoning Ordinance

1. The proposed shopping center use is not a permitted use in the Limited Commercial District (135-122.C).
2. The proposed vehicular fuel pump use is not a permitted use in the Limited Commercial District (135-122.C & 135-256.A(3)).
3. A retail store in excess of 10,000 square feet of floor area is a Special Exception use in the Limited Commercial District (135-123.B).
4. Vehicle stacking lanes shall be separated from other vehicle circulation lanes and parking areas (135-255.C). The proposed drive-throughs shall meet this requirement.
5. The proposed floor area of a retail store in the Limited Commercial District shall not exceed 50,000 square feet of gross floor area (135-256.A(1)). The gross area of the proposed retail stores does not meet this requirement.
6. The proposed bus stop location shall be reviewed and acceptable to the Red Rose Transit Authority (135-256.C(3)). The Authority has provided a letter dated February 24, 2023 confirming the feasibility of a bus stop at this site, but further coordination is needed during the land development process.
7. The proposed shopping center shall provide safe and convenient pedestrian linkages to the nearby commercial developments (i.e. Turkey Hill and Rheems Retail Center) (135-256.C(5)).

8. The applicant shall demonstrate that the proposed nonresidential use is compliant with the access management requirements found in Section 135-326.A(1) or (2) which requires access from a side street (for a corner lot) or only one shared access drive onto arterial roads.
9. The final subdivision and land development design for the proposed development shall meet all streetscape detail requirements for retail stores and shopping centers in excess of 10,000 square feet of gross floor area (135-256.E(6)).
10. A minimum of a five-foot-wide planting strip shall be provided between the back of the curb and the edge of the sidewalk along the street right-of-way (135- 256.E(6)(b)).
11. A cross access easement agreement shall be executed for the shared access drive (135-294.A).
12. An exterior lighting plan shall be submitted (135-298.D).
13. All nonresidential uses shall contain a landscape screen when such use is adjacent to a property that is available for residential use (i.e. the Ag district) (135-299.C(1)).
14. A cross access easement and maintenance agreement in a form acceptable to the Township Solicitor shall be executed and recorded (135-321.C & 135-344.C).
15. Off street loading space information shall be shown on the plans (135-346).
16. Evidence shall be provided that the proposed loading areas for deliveries and for trash pickup on are adequate in size and can be used without blocking or interfering with internal circulation (135-346.A).
17. A landscape screen shall be provided for off-street loading facilities adjoining public street rights-of-way (135-346.C). A landscape screen shall be provided between the loading docks for the retail stores E-2 through E-4 and Norlanco Drive.

Subdivision and Land Development Ordinance - Sketch plan requirements

18. Distances and bearings for the entire site boundary shall be shown on the plan (119-31.A(2)). Tracts 1 and 2 of the Elizabethtown Mount Joy Associates, L.P. property shall meet this requirement.
19. The plans shall be presented in a clear, legible, coherent and organized manner. Due to the scale of the plans, some of the text and markings are unclear, especially labels of existing features on adjacent properties. It is recommended that a linetype and symbol legend be added to the plans (119-31.A(4)).
20. The plans shall be signed and sealed by a registered engineer, surveyor or landscape architect (119-31.A(5)).
21. Norlanco Drive is proposed on Tracts 1 and 2 of the Elizabethtown Mount Joy Associates, L.P. property; therefore, these properties shall be listed as subject tracts (119-31.B(3)).
22. The applicant shall confirm whether there will be grading on the adjacent Tyson Foods, Inc. property. If grading will occur on the Tyson Foods, Inc. property, it shall be listed as a subject tract. Alternatively, an easement could be provided for the proposed grading (119-31.B(3)).
23. A location map shall be shown on the plan (119-31.B(8)).
24. The tax parcel identification number shown in the "Owners: Tract 1 and Tract 2" title block shall be corrected (119-31.B(10)).

25. The plan shall identify all prior plans, including all notes or restrictions affecting the current development, with a verification signed by the design professional that such list is complete and correct (119-31.B(14)).
26. The dimensions of the proposed right-of-way and cartway for Cloverleaf Road shall be shown on the plans (119-31.B(18)).
27. The dimensions of the existing rights-of-way and cartways for the existing streets shall be shown on the plans (119-33.C(2)(a)).
28. The location of the existing stormwater facilities, as well as the easements for the on-lot septic on Tract 1 of the Elizabethtown Mount Joy Associates, L.P. property, shall be shown on the plans (119-33.C(2)(a)).
29. The right-of-way of the existing water main along Cloverleaf Road (S.R. 4025) shall be dimensioned (119-33.C(2)(a)).
30. The existing access drives within 200 feet of the subject tracts shall be dimensioned. The rights-of-way and cartways for the existing streets within 200 feet of the subject tracts shall be dimensioned (119-33.C(3)(a)).
31. The zoning requirements, as well as the proposed conditions, shall be added to the Zoning Data table for the Agricultural District for Tracts 1 and 2 of the Elizabethtown Mount Joy Associates, L.P. property. The proposed conditions shall be added to the Zoning Data table for the Limited Commercial District for the Elizabethtown Associates property (119-33.D(2)).
32. The applicant shall confirm the units of occupancy shown in the Site Data table (119-33.D(4)). The table indicates that eleven (11) units are proposed; however, only nine (9) are shown on the plan.
33. The total number of lots (existing and proposed) and the density shown in the Site Data table on the Cover Sheet shall be corrected (119-33.D(4)). Tracts 1 and 2 of the Elizabethtown Mount Joy Associates, L.P. property shall be added to the Site Data table.
34. The proposed cartway widths near the cartway tapers on Cloverleaf Road shall be shown on the plans (119-33.D(5)).
35. The length of the taper on Cloverleaf Road near proposed Access Drive 'C' shall be shown on the plans (119-33.D(5)).
36. Building setback lines shall be shown on the plans for Tracts 1 and 2. The side and rear yard building setback lines shall be shown for the tracts of land between the western proposed right-of-way line of Norlanco Drive and the eastern property line of the Elizabethtown Associates property (119-33.D(7)).
37. The location of any recreation or open space land to be provided shall be shown on the plan (119-33.D(11)). The plans should also indicate whether the developer intends to dedicate required recreation and open space land or pay a fee in lieu of dedication.
38. The Official Map shows a proposed trail to be located along West Main Street (SR 320). The location of the proposed trail shall be shown on the plans (119-33.D(12)).

Subdivision and Land Development Ordinance - Land development requirements

39. Evidence shall be provided with the land development submission to confirm that sufficient taper lengths for West Main Street and Cloverleaf Road have been provided (119-51.A(2)).

40. Building setback lines be shown for the Tyson Foods, Inc. property on the east side of the proposed Norlanco Drive (119-52.I(2)).
41. The frontage along West Main Street (SR 230), Cloverleaf Road (SR 4025), and Ridge Run Road shall be improved in accordance with 119-52.J or as indicated on the Township Official Map, whichever is greater. The required right-of-way indicated on the Official Map is 120 feet for West Main Street at the Cloverleaf/Colebrook Road and West Main Street intersection, 100 feet for Cloverleaf Road and West Main Street (along the lot frontage that is not for the aforementioned intersection improvements), and 60 feet for Ridge Run Road. Concrete curbing, concrete sidewalk, and pavement widening (if necessary) shall be provided along Ridge Run Road. Concrete curbing shall be provided along the entire frontage of West Main Street (SR 230). Improvements indicated on the Official Map include construction of a multi-use trail along West Main Street, a second through lane for West Main Street, a westbound left turn phase on West Main Street, and a second through lane for Cloverleaf Road (119-52.J(3)(a) & 119-53.B(2) / 119-53.C).
42. The developer shall take all necessary action to obtain PennDOT permits and/or approvals to install the necessary improvements to the state roadways (119-52.J(3)(e)).
43. Streetlighting shall be provided along new streets located within the designated growth area (119-52.O). Norlanco Drive shall meet this requirement.
44. No more than two access drives shall be located on a single street frontage (119-52.S(3)(g)). The access drives on Norlanco Drive shall meet this requirement.
45. The applicant shall address the traffic engineering comments provided by Traffic Planning and Design under separate cover (119-52.S(4)(c)).
46. Evidence shall be provided that the proposed loading areas for deliveries and for trash pickup on are adequate in size and can be used without blocking or interfering with internal circulation (119-52.S(6)).
47. Sidewalks shall be provided along both sides of Norlanco Drive for the entire length of the street (119-53.B(1)).
48. Sidewalks shall be provided along both sides of Access Drives A, B, and C for the entire length of the access drives (119-53.B(1)). The unlabeled access drives shall also meet this requirement.
49. Curbing shall be provided along both sides of Norlanco Drive (119-53.C(1)).
50. Street trees shall be provided along both sides of Norlanco Drive (119-59.G).

Traffic

51. The proposed development is located within the Transportation Service Area established for the Mount Joy Township Traffic Impact Fee Ordinance. Therefore, the development shall be assessed a traffic impact fee based on the number of new P.M. peak hour trips generated by the development.

The impact fee is payable at the time of building permit issuance.

If you should have any questions or need additional information, please do not hesitate to contact me at bencraddock@lancastercivil.com or via telephone at 717-799-8599.

Sincerely,

A handwritten signature in blue ink that reads "Benjamin S Craddock". The signature is written in a cursive style.

Benjamin S. Craddock, PE, President

LANCASTER CIVIL

cc: Patricia Bailey, Township Secretary (via email)
Josele Cleary, Esquire, Township Solicitor (via email)
Christopher Lincoln, PE, Traffic Planning & Design (via email)
Bob Sichelstiel, Penmark Properties (via email)
Dean Cafiero, Penmark Properties (via email)
Justin Bartholomew, Penmark Properties (via email)
Todd Smeigh, DC Gohn Associates (via email)
Brian Cooley, DC Gohn Associates (via email)